



Leica DMI3000 B

Manual Inverted Research Microscopes for Life Sciences

Living up to Life

Leica
MICROSYSTEMS

The Perfect Start to Research Microscopy

Versatility in transmitted light

The Leica DMI3000 B offers a level of technology, functionality, and user convenience that is unique in this class of inverted research microscope. Featuring the largest number of transmitted light illumination options and a condenser with extra long working distance, the Leica DMI3000 B is ideal for all transmitted light contrast techniques. Choose from five manual condensers with different working distances for brightfield, phase contrast, dark-field, modulation contrast, polarization or differential interference contrast (DIC) techniques. Leica's integrated modulation and phase contrast solutions eliminate the need for additional special objectives and increase throughput in fluorescence.

Brilliant fluorescence

The new Leica DMI3000 B is designed for all fluorescence techniques, and accommodates standard and custom filter cubes in the 5-position fluorescence turret. Single or multiple stains, GFP applications, and immunofluorescence – all are accomplished quickly and easily with the Leica DMI3000 B. Leica's fluorescence intensity manager (FIM) automatically adjusts the illumination intensity as well as the aperture and field diaphragms to optimize your images. The fluorescence cubes feature light traps for reducing background light to produce a perfectly black background.

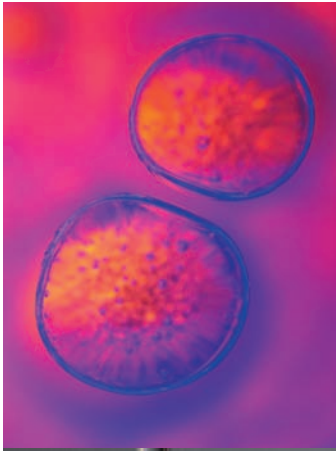



Leica Design by Christophe Apothéoz

User-friendly Through Ergonomic Design

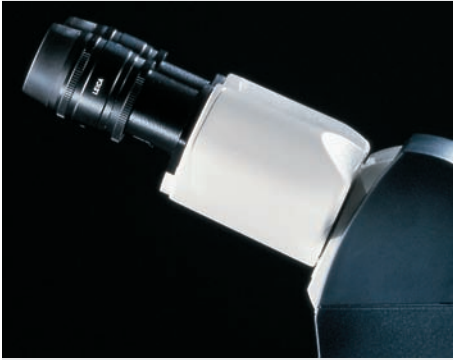

Ergonomic tube

The Leica DMI3000 B is equipped with an ergonomic tube. The continuous adjustment of the eyepieces ensures the best viewing angles for all users, while the “viewing channel,” integrated within the tube, provides a clear, unobstructed view of the specimen at all times and allows the user to switch from microscopic to visual observation of the specimen at any time without changing the tube setting.



Unobstructed view of the specimen

The “viewing channel” integrated in the tube provides a clear view of your specimen, and lets you switch from microscopic to visual observation of your specimens at any time without changing the tube setting.

Ergonomics is a word often associated with ease of use. With the Leica DMI3000 B, ergonomic design means a user-friendly microscope system that the researcher can actually feel. The Leica DigitalMicroscope line not only exceeds the latest technical standards, it also more than fulfills the highest standards of ergonomic design.

Versatility – the art of creating brilliant images

The versatile Leica DMI3000 B supports all transmitted light methods – and more. Its integrated interpupillary interface and unparalleled contrast possibilities allow the user to create brilliant images.

Adaptive, yet individual

Every experiment is unique and the microscope should be as well. Leica Microsystems cooperates closely with accessory manufacturers in order to provide a unique, perfectly integrated microscope system for every user. This ensures that all accessories will integrate reliably with the Leica DMI3000 B system.

Work in comfort ...

The ergonomic tube is a standard feature of the Leica DMI3000 B. To make work at the microscope as comfortable as possible, the viewing angle can be continuously re-adjusted and adapted to suit the user’s seated height and interpupillary distance. The stability is built into the mechanics of the microscope. Robust mechanisms and precise metal joints ensure reliable, exact settings.

... with nothing to obstruct the view

There’s no substitute for an unobstructed view of the specimen. Leica’s “viewing channel,” located between the eyepieces, provides a clear view of the specimen at all times. The optional photo exit is also situated on the side of the tube for this reason. This is an advantage when working with micro tools such as needles or probes.

Convenient operation

Leica's DigitalMicroscopes were developed in cooperation with engineers of the Fraunhofer Institute IAO* to ensure the highest standards of ergonomic design. As a result, all of the Leica DMI3000 B's controls are easily accessible. The positioning is so natural that the user can reach the focus knobs without looking.

Natural feel

The focus knobs are also ergonomically shaped to comfortably fit in the user's hand. The flat focus knob on the right-hand side has two advantages: it allows one-handed operation of both the stage and focus, and it prevents interference of the stage drive and focus controls.



Convenience in every detail

- Individually configured, upgradeable microscope system
- Ergonomic tube
- Viewing channel
- Easily accessed controls
- One-handed operation



One-hand operation

The Leica DMI3000 B's stage drive and focus knob are positioned closely to one another for convenient, one-handed operation.

Experience and Innovation – the Art of Creating Brilliant Images



C. elegans recorded with
Differential Interference Contrast (DIC)
Image source: IGBMC, Strasbourg, France

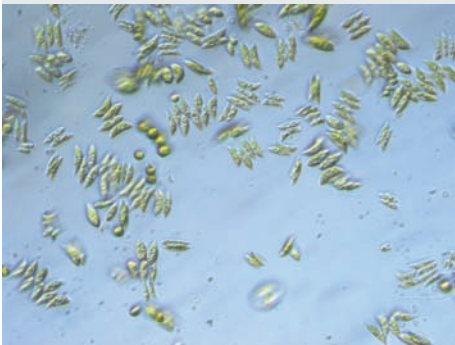

Water sample from the fishing pond in Braunfels,
Germany, Intermediate Modulation Contrast (IMC)

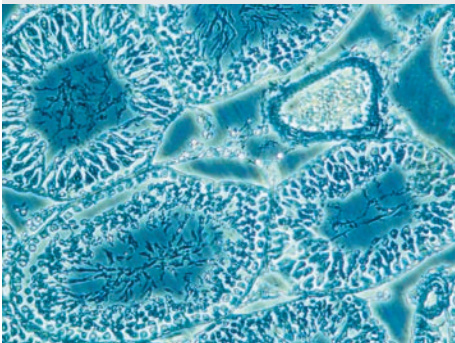

Rat testicles, Intermediate Phase Contrast (IPH)

High contrast and resolution for every specimen –

Leica's new differential interference contrast (DIC)

It's a familiar phenomenon when using DIC: improved contrast results in lower resolution and vice versa. This effect is more pronounced when observing specimens that are unusually thick or thin. Leica offers special prism combinations for viewing 'normally' thick, especially thick, and especially thin specimens.

Leica's affordable, new intermediate modulation contrast (IMC)

Leica offers an intermediate interpupillary interface, which is an effective, yet affordable, intermediate modulation contrast solution with brightfield objectives. Perfect for imaging specimens in plastic dishes, modulation contrast is no longer an expensive technique.

Leica's new intermediate phase contrast (IPH)

Now available: a solution for phase contrast using brightfield objectives that does not require the use of special objectives outfit with phase rings. Leica has applied the intermediate interpupillary interface to another revolutionary contrast method, intermediate phase contrast (IPH). IPH is the first phase contrast technique by which the user can influence the contrast – using normal objectives. This reduces system cost and improves fluorescence performance.

Condensers for every type of contrast technique

Leica has added a special condenser for micromanipulation with a free working distance of 40 mm to its wide selection of condensers. This special condenser is suitable for conventional phase and modulation contrast as well as for IPH and IMC. Leica offers a choice of five different condensers with different working distances (1, 23, 28, 40 and 70 mm).

When less is more

For the more budget-conscious user, the Leica DMI3000 B offers a transmitted light arm with an integrated 30 W lamp house. This rounds out the range of Leica illumination arms with interchangeable lamp houses and provides a solution for every budget.

Individually Configured for Specific Research

Wide variety of stages

The Leica DMI3000 B can be configured with any one of a wide variety of specimen stages. Choose among fixed and 3-plate cross-stages. Motorized stages can also be used. A special development for the Leica DMI3000 B: an extra-narrow, 3-plate cross-stage for micromanipulation that provides ample room for accessories.

Like an extra hand

For cell manipulation – transgenic manipulation or protein, dye, or drug compound injection – Leica's mechanical micromanipulators are unparalleled in precision and quality. The mechanical micromanipulators adapt seamlessly to the Leica DMI3000 B. Suitable adapters for electronic and hydraulic micromanipulators are also available.

Many temperatures are possible

Stage inserts to accommodate all types of containers, combined with temperature control units, ensure the correct environment for all experiments. From below freezing to +60° C, many temperatures are possible. Simply choose the accessories that best suit the research requirements.

Everything under control

A comprehensive range of environmental control equipment is available for the Leica DMI3000 B. Carbon dioxide control units maintain constant pH values. Oxygen controllers regulate O₂ concentration. Temperature regulators are also available to help maintain the required physiological temperature.

Perfect climate

Many specimens require defined, precisely-regulated environmental conditions during an experiment. The Leica DMI3000 B offers everything needed in this respect. Leica climate chambers are available in a variety of sizes – from models designed to accommodate a single Petri dish to a climate chamber that encloses the entire microscope system.



Leica micromanipulators

Leica's mechanical micromanipulators are very convenient to use because of the hanging joystick. The joystick is absolutely precise and direct in its action.



Transmitted light arm with integrated 30 W lamp house and compact S40/0.50 condenser, specifically for micromanipulation.

Micromanipulation

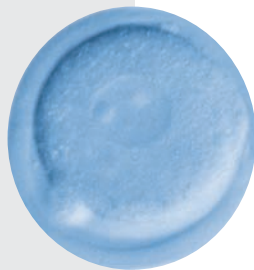

Leica DMI3000 B inverted microscope

- The micromanipulation stage with its slim design allows easy adaptation of micromanipulators.
- At 28 mm, the S28 condenser provides ample working distance for micromanipulation using all contrast techniques. If more working distance is required, the S40 condenser with 40 mm working distance is available for all contrast techniques except DIC; and the S70 condenser with 70 mm working distance is available for all contrast techniques except IMC/IPH.
- Two different transmitted light arms are available:
 - 12 V/100 W, which adapts to all Leica lamp houses
 - 12 V/30 W with integrated lamp house

Micromanipulation must be properly configured on a microscope system. The system shown below is an integrated solution consisting of a Leica DMI3000 B inverted microscope and Narishige micro-manipulation equipment.

Narishige micromanipulators

- Narishige's new micromanipulators feature a compact, rugged design for stability.
- The short distance to the tip of the pipette minimizes vibration.
- The micromanipulators can be universally deployed on both sides.
- The hanging joystick provides a relaxed hand position and sensitive control.



Integrated Modulation Contrast (IMC)

Leica DMI3000 B inverted microscope

- Leica's IMC modulator is integrated within the light path, outside the objective, in a focal plane conjugate to the condenser (intermediate interpupillary interface).
- One objective series is all that is required for all contrast techniques without transmission loss in fluorescence; no need for additional special objectives.
- Freely accessible modulators allow fast, individual contrast adjustment.
- There is no change in 3D image impression when objectives or magnifications are changed – no need to make additional adjustments.
- The telescope system features optimum monochromatic and chromatic correction to minimize stray light.

Individually modifiable IMC parameters:

- Homogeneity
- Resolution
- Contrast intensity
- Relief impression

IMC is ideal for unstained, low-contrast biological specimens in plastic dishes. Because of the integration of a modulator into the light path – an innovation of Leica Microsystems – this method is very easy to use and flexible in its application. Instead of a few special objectives, a wide variety of brightfield or phase objectives can be used. For the first time, the contrast can be individually modified and optimized by freely accessible modulators.

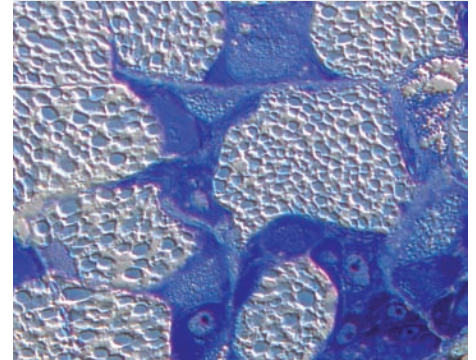

Theodoxus, protein gland.
Toluidin blue staining of a histology section
after embedding in methacrylate.



Hard, contrast-pronounced modulation contrast



Soft modulation contrast

Photos: C. Mehnert, Center for In-Vitro Fertilization,
Giessen, Germany

Heating and Environment

Incubation systems are fundamental for live cell recording. The system below consists of a Leica DMI3000 B inverted microscope, BL incubator, and heating unit. Leica Microsystems recommends a DFC digital camera such as the universal Leica DFC480 color camera; or the monochrome Leica DFC350 FX camera, designed specifically for fluorescence applications.

Leica DMI3000 B inverted microscope

- The heating stage, or heating inserts with CO₂ cover, ensures optimal experimental conditions for cells.
- The temperature in the sealed chamber can be held constant at up to 37°C above room temperature.
- Fresh air availability is assured because of the large ventilation hoses.
- The temperature sensors can be positioned and attached anywhere in the climate chamber.
- Leica's BL incubator is the only climate chamber that completely accommodates accessories such as Eppendorf micromanipulators, scanning stages, and 3-plate cross-stages.
- The large access openings allow convenient access to the microscope and tools inside the chamber.
- The top port with a Leica DFC digital camera features a FireWire port for convenient, fast image transfer.



Fluorescence Observation

Leica DMI3000 B inverted microscope

- The manual fluorescence axis consists of the filter cube changer, aperture diaphragm, and field diaphragm.
- The 5-position filter cube turret and removable drawer offer ample space for a variety of fluorescence experiments.
- Leica's Fluorescence Intensity Manager (FIM) regulates the excitation light to effectively protect specimens from photo bleaching.
- The integrated shutter quickly stops-off illumination.
- Leica's Zero Pixel Shift filter cube technology ensures perfect image alignment of multiple fluorescence proteins, which makes software overlay compensation unnecessary.

Leica DFC340 FX digital camera

- This digital camera features a FireWire port for fast image transfer.
- The cooled monochrome chip provides high resolution and noise reduction when imaging fluorescence.

Leica AF6000 E fluorescence software

- This fluorescence application software includes driver modules for the camera.
- The software features an entirely new, intuitive graphical user interface that guides users through experiments.
- A variety of software modules with magnification tools, image measurement, and presentation options round out the software package.

Fluorescence observation is standard practice now for viewing live cells. The system below consists of a Leica DMI3000 B inverted microscope with fluorescence, a Leica DFC340 FX digital fluorescence camera, and Leica AF6000 E fluorescence software. A system of this type is ideal for recording, archiving, and processing fluorescence images.

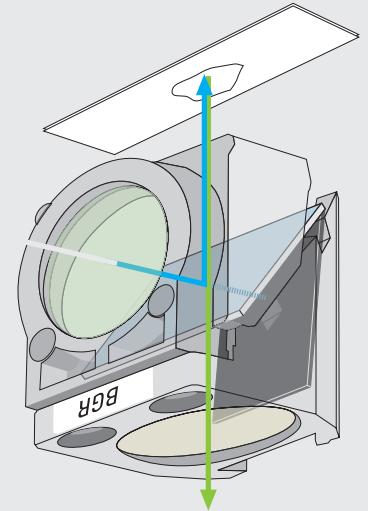

Triple bandpass filter (BGR)



5-position manual fluorescence turret

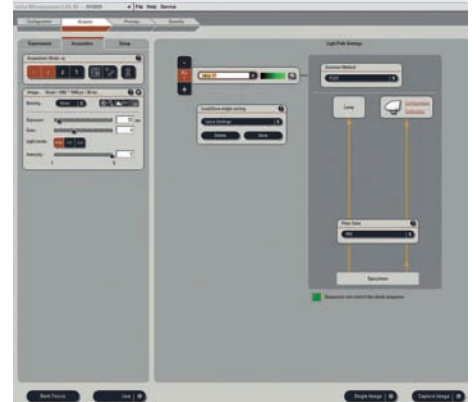

Leica AF6000 E software interface

		Leica DMI3000 B for Transmitted Light only	Leica DMI3000 B for Transmitted Light and Fluorescence
Stand	Power supply	<ul style="list-style-type: none"> • 30 W or 100 W in stand 	<ul style="list-style-type: none"> • 30 W or 100 W in stand
Optic carrier	Integrated contrast techniques	<ul style="list-style-type: none"> • optional with or without IMC • optional with or without IPH 	<ul style="list-style-type: none"> • optional with or without IMC • optional with or without IPH
Focus		<ul style="list-style-type: none"> • mechanical • coarse and fine drives 	<ul style="list-style-type: none"> • mechanical • coarse and fine drives
Objective turret		<ul style="list-style-type: none"> • 6-position M25 • mechanical 	<ul style="list-style-type: none"> • 6-position M25 • mechanical
Stages	Mechanical stages	<ul style="list-style-type: none"> • fixed stages <ul style="list-style-type: none"> – various sizes • Object guides <ul style="list-style-type: none"> – over 20 different inserts available – heating and cooling inserts • 2 different 3-plate plate-stages 	<ul style="list-style-type: none"> • mechanical <ul style="list-style-type: none"> – various sizes • Object guides <ul style="list-style-type: none"> – over 20 different inserts available – heating and cooling inserts • 2 different 3-plate plate-stages
Transmitted light axes	Illumination arm	<ul style="list-style-type: none"> • for 12 V/100 W halogen lamp with <ul style="list-style-type: none"> – manual field diaphragm – filter magazine for 2 filters, mechanical – manual shutter • 12 V/30 W halogen <ul style="list-style-type: none"> – including lamp house – filter magazine for 2 filters, mechanical – manual shutter 	<ul style="list-style-type: none"> • for 12 V/100 W halogen lamp with <ul style="list-style-type: none"> – manual field diaphragm – filter magazine for 2 filters, mechanical – manual shutter • 12 V/30 W halogen <ul style="list-style-type: none"> – including lamp house – filter magazine for 2 filters, mechanical – manual shutter
Condensers	<p>S1 oil 1.4</p> <p>S1 dry 0.9</p> <p>S23 0.52</p> <p>S28 0.55</p> <p>S40 0.50</p> <p>S70 0.23</p>	<ul style="list-style-type: none"> • manual condenser disk for optical elements like prisms, DF stop, PH rings, modulators • integrated manual aperture diaphragm • separate manual polarizer (optional) • manual flip-top condenser head • fixed condenser head • manual flip-top condenser head • fixed condenser head • manual flip-top condenser head • fixed condenser head • fixed condenser head • fixed condenser head • fixed condenser head 	<ul style="list-style-type: none"> • manual condenser disk for optical elements like prisms, DF stop, PH rings, modulators • integrated manual aperture diaphragm • separate manual polarizer (optional) • manual flip-top condenser head • fixed condenser head • manual flip-top condenser head • fixed condenser head • manual flip-top condenser head • fixed condenser head • fixed condenser head • fixed condenser head • fixed condenser head
Fluorescence	<p>Filter turret</p> <p>Fluorescence axis</p>		<ul style="list-style-type: none"> • manual • for up to 5 filters • Fluorescence Intensity Manager (FIM) • adjustable aperture and field diaphragm • 1" collector • shutter

Specifications

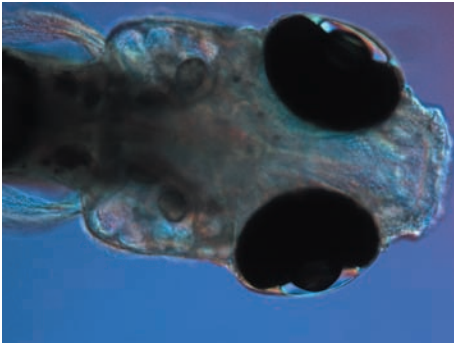
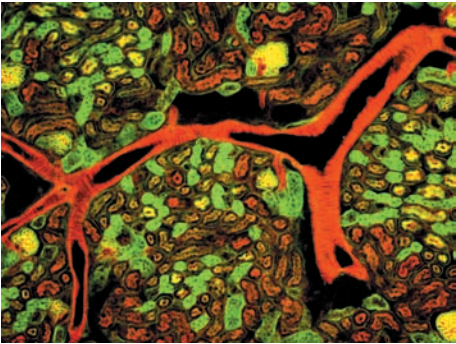
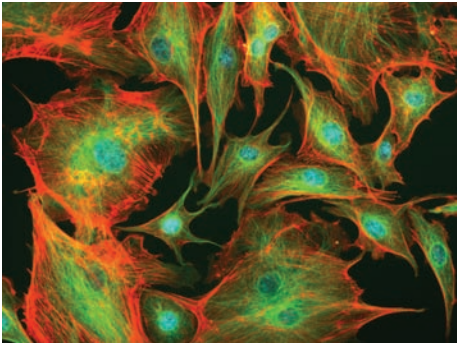
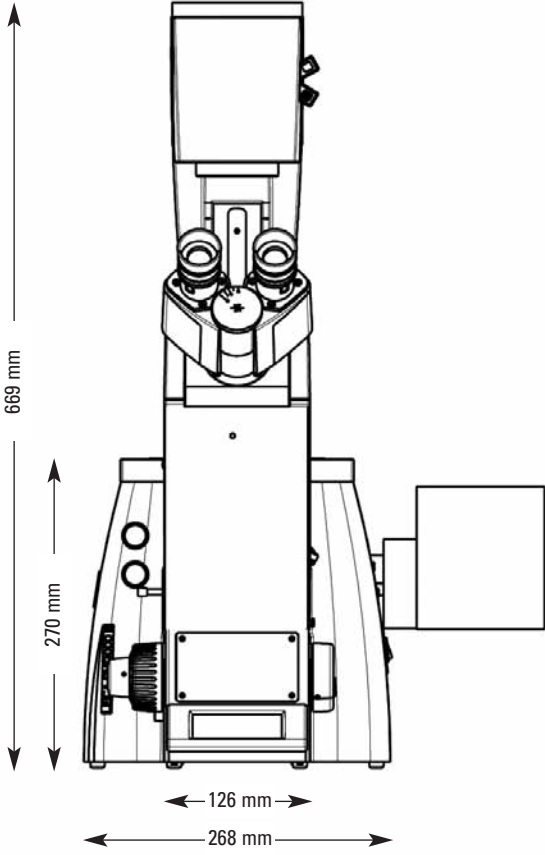
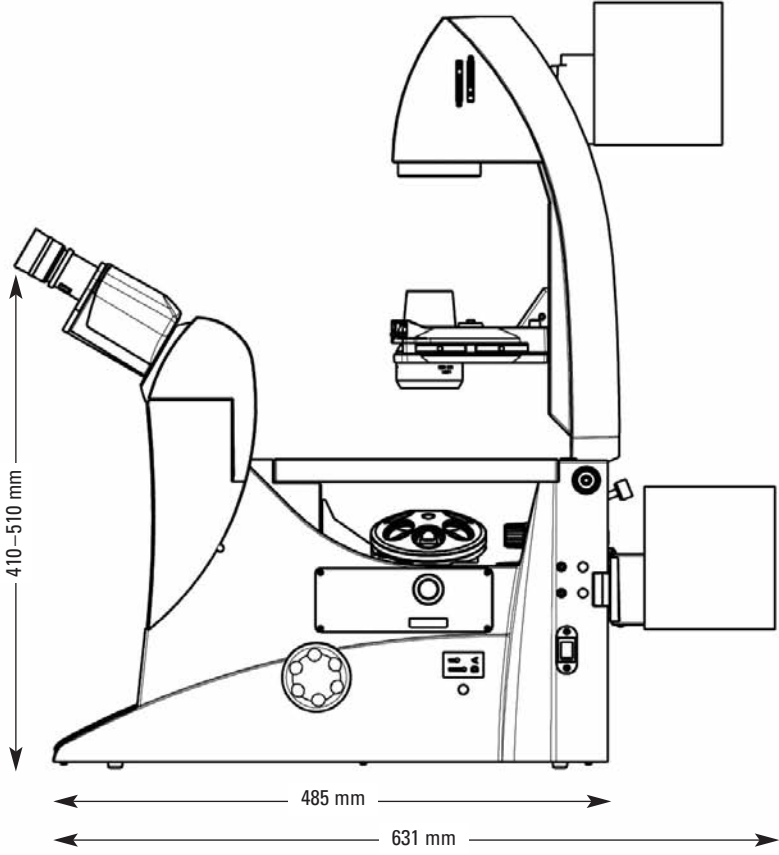

System Overview

Leica DMI3000 B, DMI4000 B and DMI6000 B

TV systems

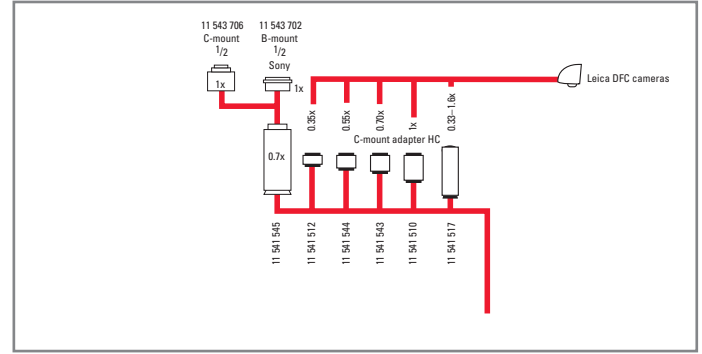

Condensers

S1-28 man. DMI3000-6000 B

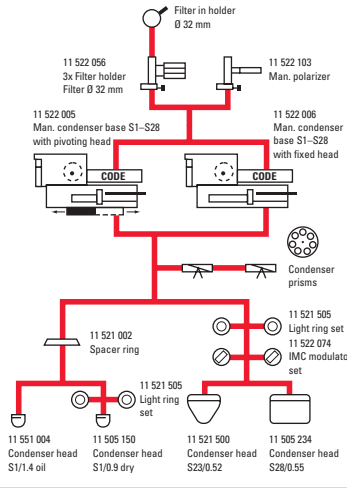

S1-28 mot. DMI4000/6000 B

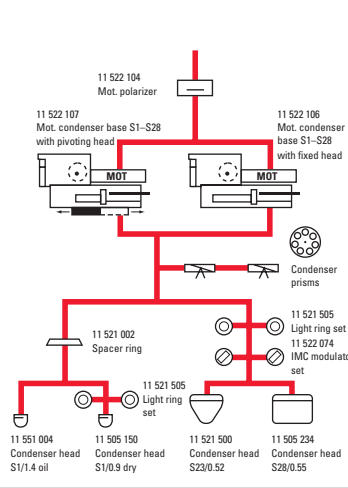

S70 mot. DMI4000/6000 B

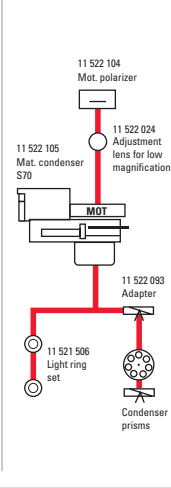

S70 man. DMI3000-6000 B

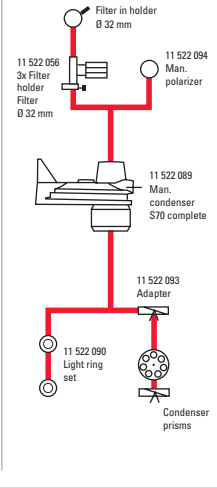

S40 man. DMI3000-6000 B

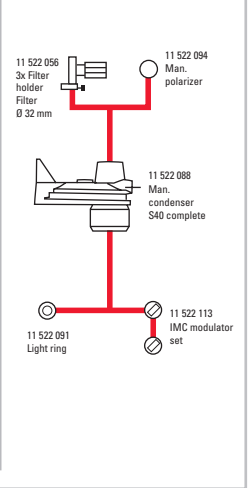

Bino FixTube

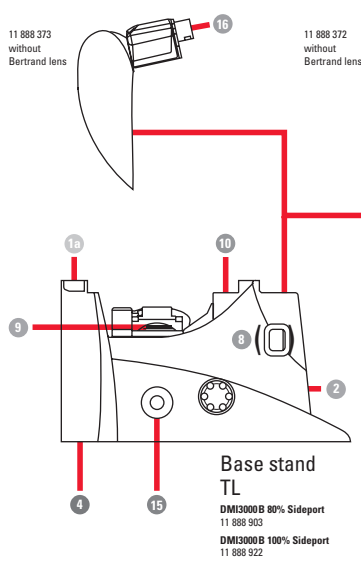

Bino ErgoTubes

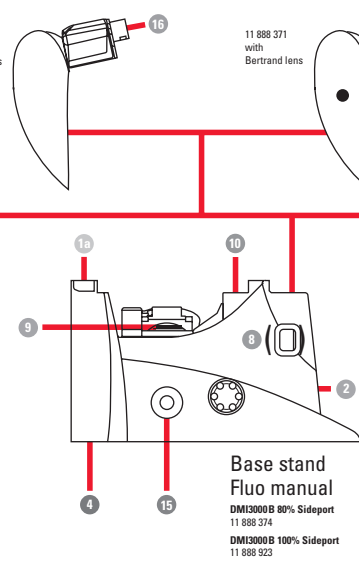

Trino ErgoTubes

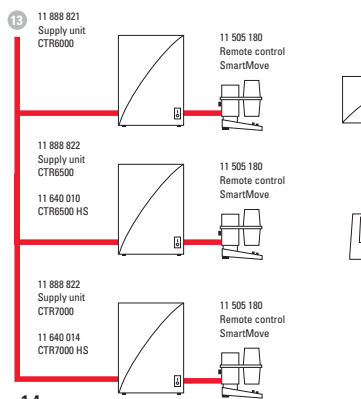
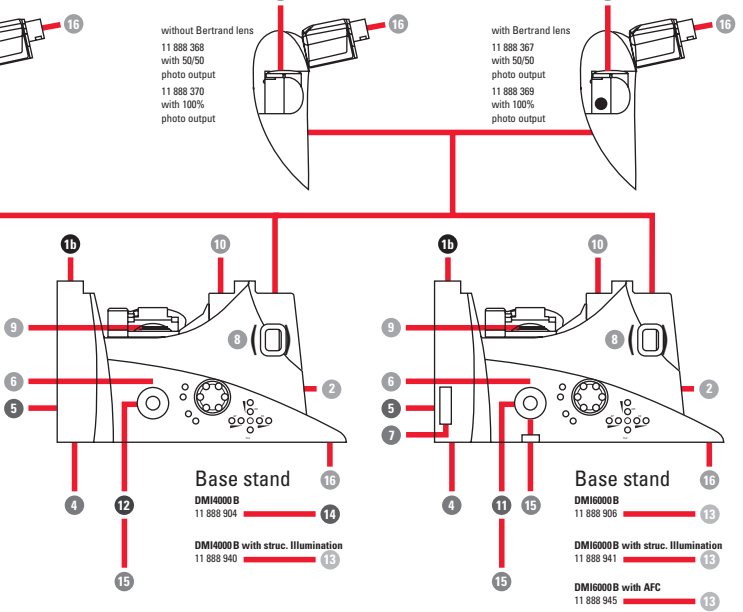

Side ports DMI6000 B

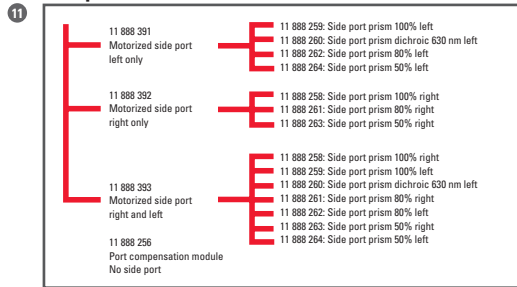

Side ports DMI4000 B

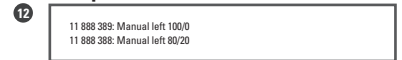

Optic carrier

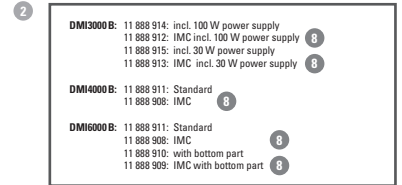

Transmitted-light axes DMI3000 B

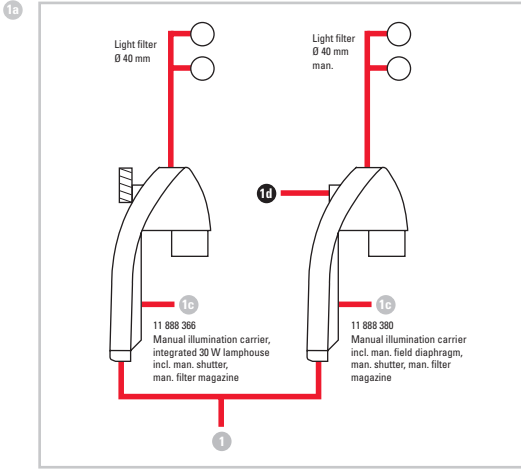

Fluorescence lamp housings

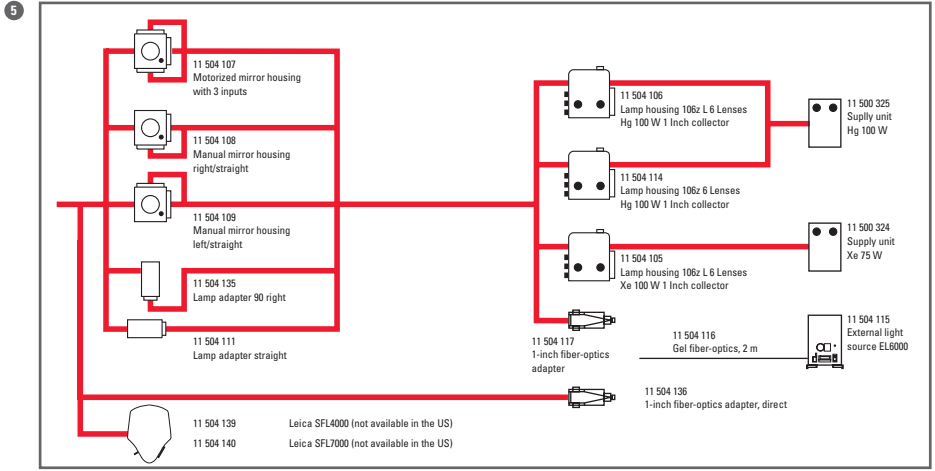

Transmitted-light axes DMI4000/6000 B

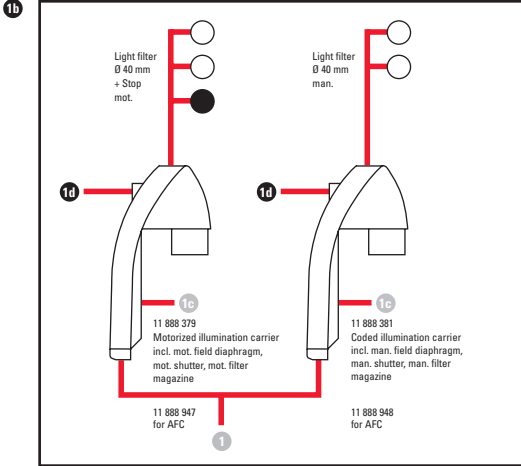

Fluorescence axes and magnification changer

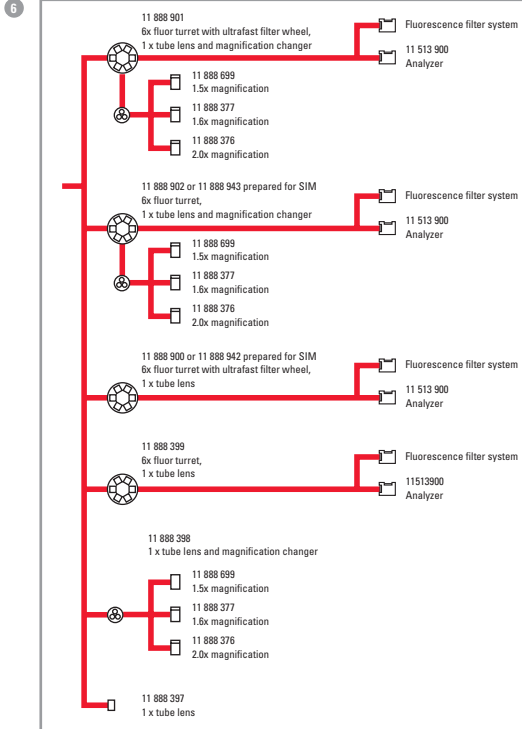

Booster optics



IMC-/IPH-Systems

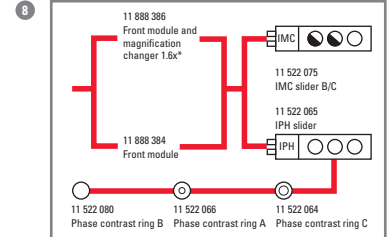

DIC systems

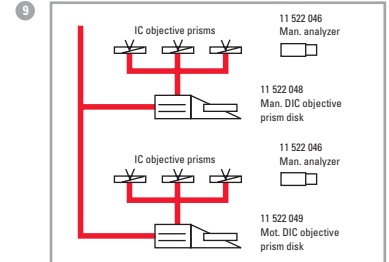

Transmitted-light lamp housings

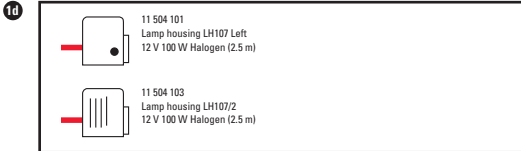

Base plate

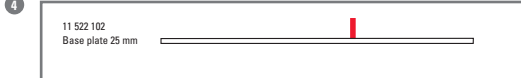

Eyepieces

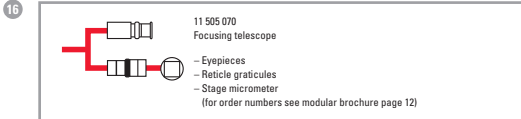

Stages

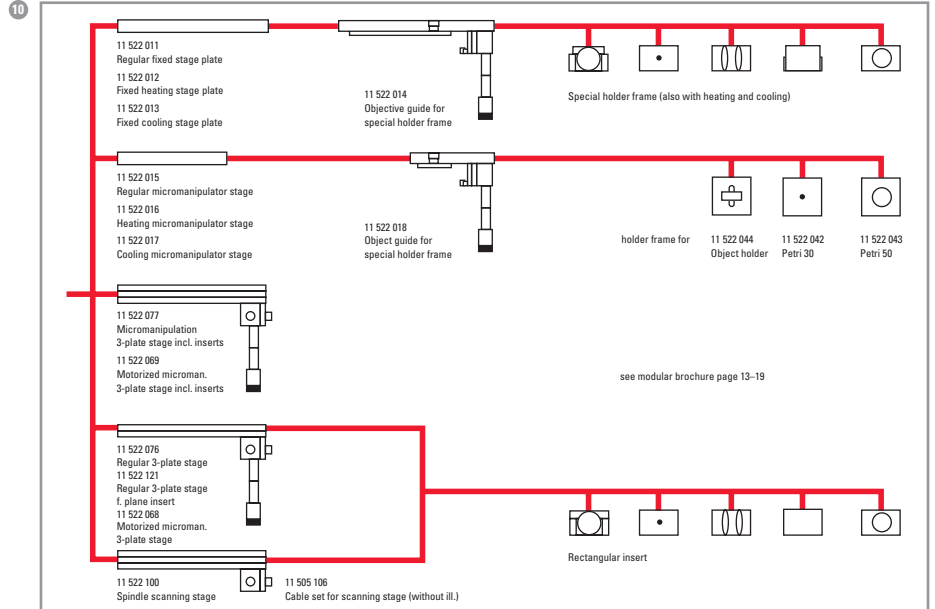

“With the user, for the user”

Leica Microsystems

Leica Microsystems operates globally in four divisions, where we rank with the market leaders.

● Life Science Division

The Leica Microsystems Life Science Division supports the imaging needs of the scientific community with advanced innovation and technical expertise for the visualization, measurement, and analysis of microstructures. Our strong focus on understanding scientific applications puts Leica Microsystems' customers at the leading edge of science.

● Industry Division

The Leica Microsystems Industry Division's focus is to support customers' pursuit of the highest quality end result. Leica Microsystems provide the best and most innovative imaging systems to see, measure, and analyze the microstructures in routine and research industrial applications, materials science, quality control, forensic science investigation, and educational applications.

● Biosystems Division

The Leica Microsystems Biosystems Division brings histopathology labs and researchers the highest-quality, most comprehensive product range. From patient to pathologist, the range includes the ideal product for each histology step and high-productivity workflow solutions for the entire lab. With complete histology systems featuring innovative automation and Novocastra™ reagents, Leica Microsystems creates better patient care through rapid turnaround, diagnostic confidence, and close customer collaboration.

● Medical Division

The Leica Microsystems Medical Division's focus is to partner with and support surgeons and their care of patients with the highest-quality, most innovative surgical microscope technology today and into the future.

The statement by Ernst Leitz in 1907, “with the user, for the user,” describes the fruitful collaboration with end users and driving force of innovation at Leica Microsystems. We have developed five brand values to live up to this tradition: Pioneering, High-end Quality, Team Spirit, Dedication to Science, and Continuous Improvement. For us, living up to these values means: **Living up to Life.**

Active worldwide

Australia:	North Ryde	Tel. +61 2 8870 3500	Fax +61 2 9878 1055
Austria:	Vienna	Tel. +43 1 486 80 50 0	Fax +43 1 486 80 50 30
Belgium:	Groot Bijgaarden	Tel. +32 2 790 98 50	Fax +32 2 790 98 68
Canada:	Richmond Hill/Ontario	Tel. +1 905 762 2000	Fax +1 905 762 8937
Denmark:	Ballerup	Tel. +45 4454 0101	Fax +45 4454 0111
France:	Nanterre Cedex	Tel. +33 811 000 664	Fax +33 1 56 05 23 23
Germany:	Wetzlar	Tel. +49 64 41 29 40 00	Fax +49 64 41 29 41 55
Italy:	Milan	Tel. +39 02 574 861	Fax +39 02 574 03392
Japan:	Tokyo	Tel. +81 3 5421 2800	Fax +81 3 5421 2896
Korea:	Seoul	Tel. +82 2 514 65 43	Fax +82 2 514 65 48
Netherlands:	Rijswijk	Tel. +31 70 4132 100	Fax +31 70 4132 109
People's Rep. of China:	Hong Kong	Tel. +852 2564 6699	Fax +852 2564 4163
Portugal:	Lisbon	Tel. +351 21 388 9112	Fax +351 21 385 4668
Singapore		Tel. +65 6779 7823	Fax +65 6773 0628
Spain:	Barcelona	Tel. +34 93 494 95 30	Fax +34 93 494 95 32
Sweden:	Kista	Tel. +46 8 625 45 45	Fax +46 8 625 45 10
Switzerland:	Heerbrugg	Tel. +41 71 726 34 34	Fax +41 71 726 34 44
United Kingdom:	Milton Keynes	Tel. +44 1908 246 246	Fax +44 1908 609 992
USA:	Bannockburn/Illinois	Tel. +1 847 405 0123	Fax +1 847 405 0164

and representatives in more than 100 countries